

Dargestellt: Abtriebsseite rechts  
Shown: Output-shaft on the right side

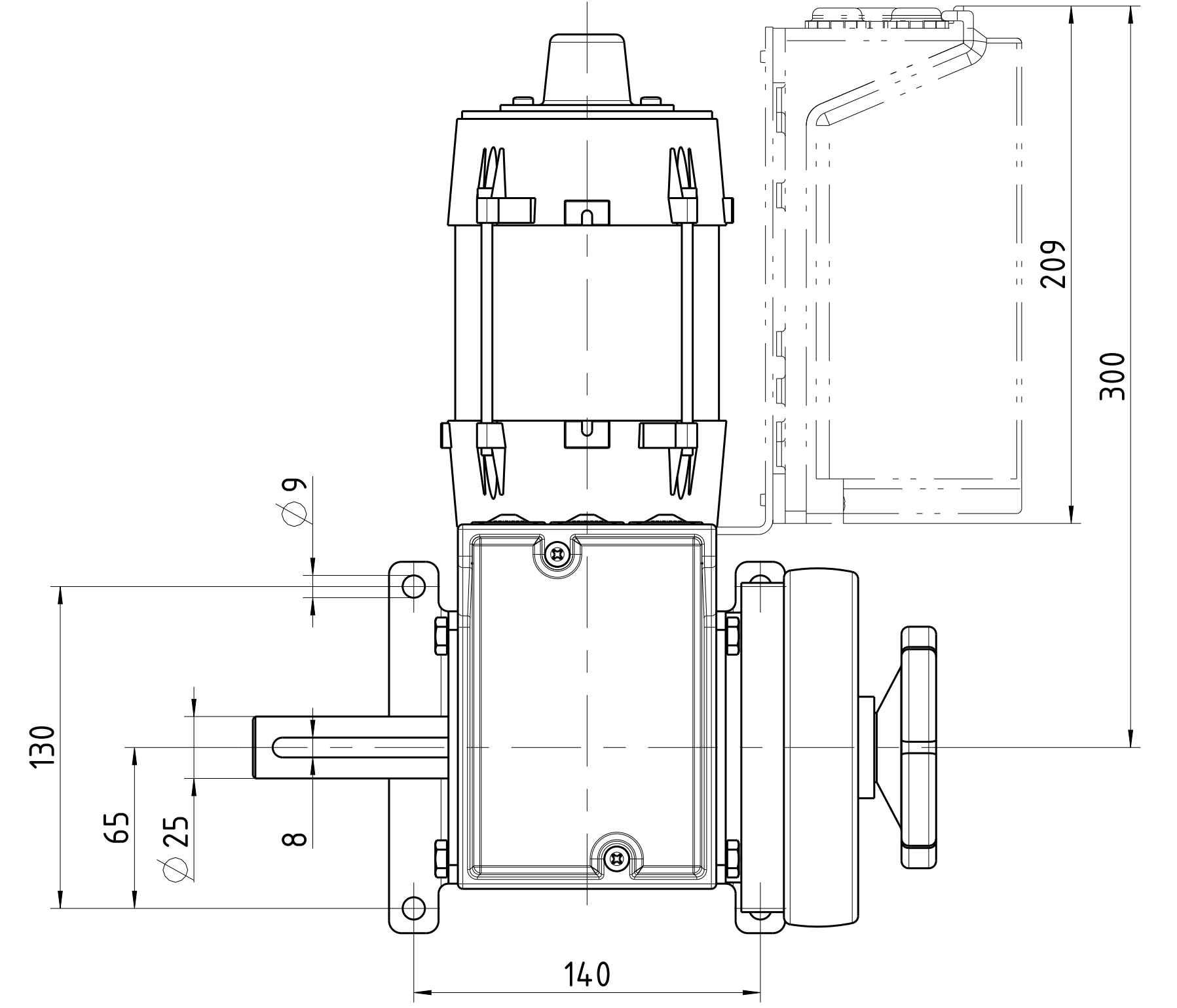

Dargestellt: Abtriebsseite rechts  
Shown: Output-shaft on the right side

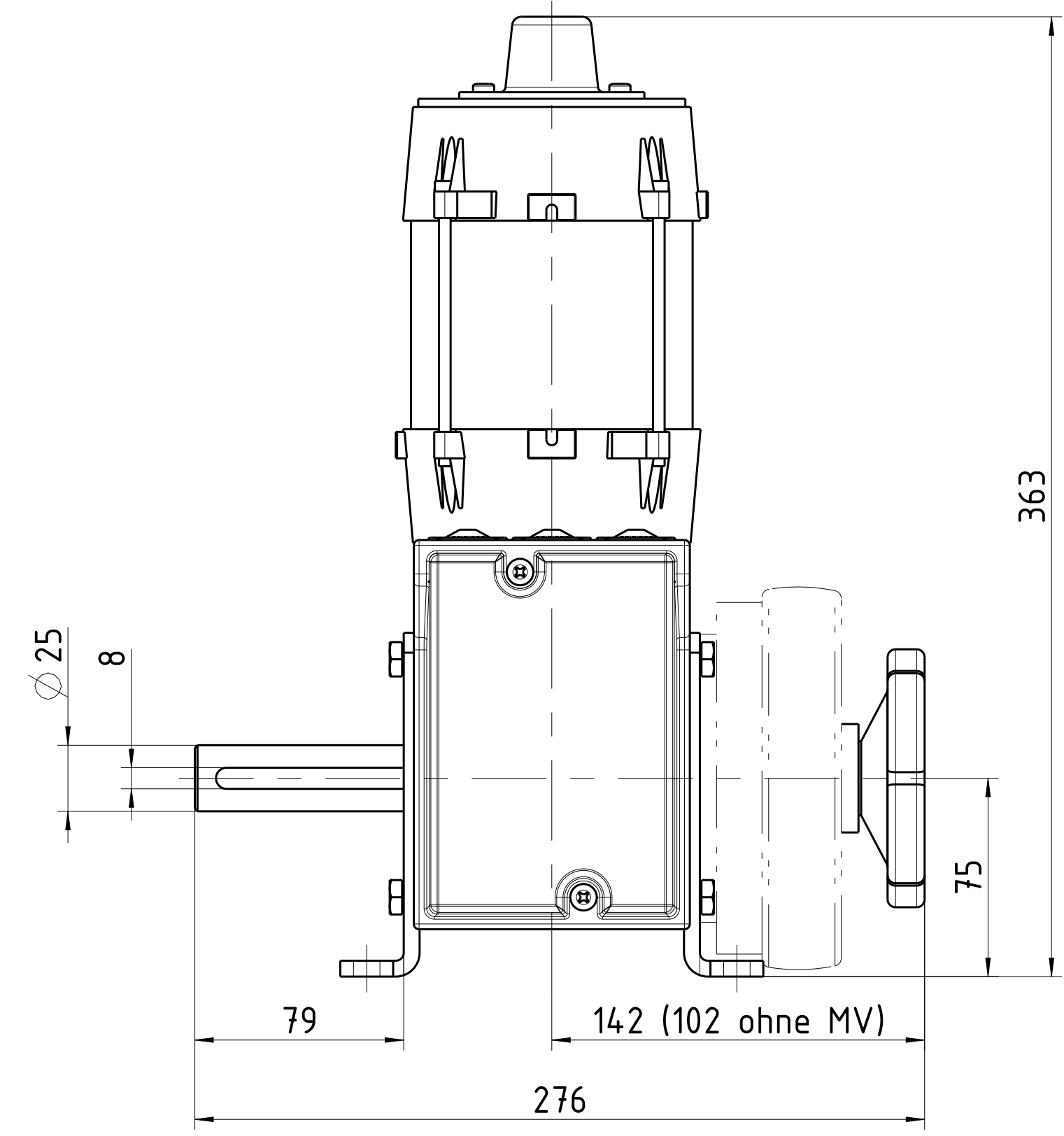
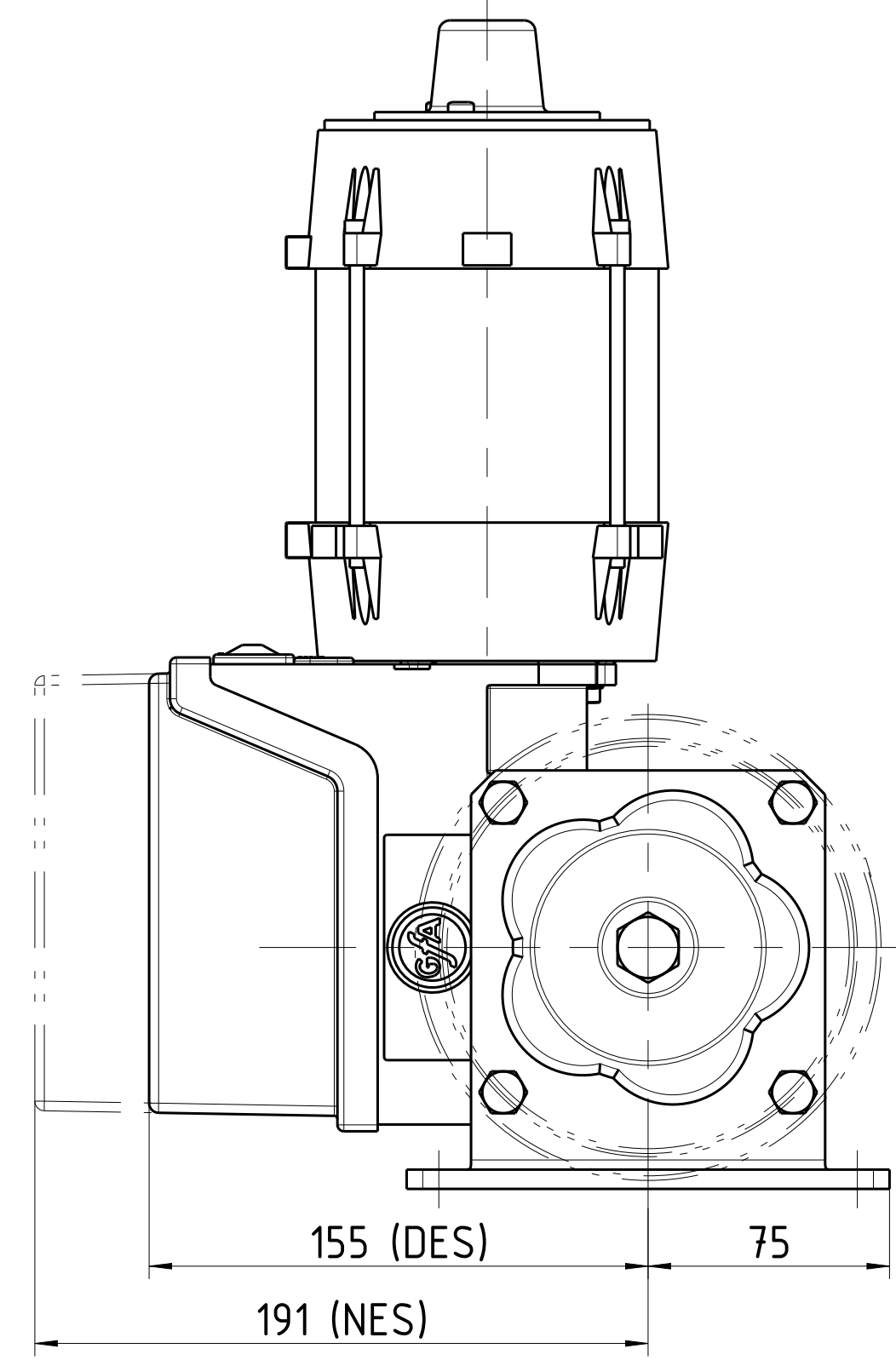
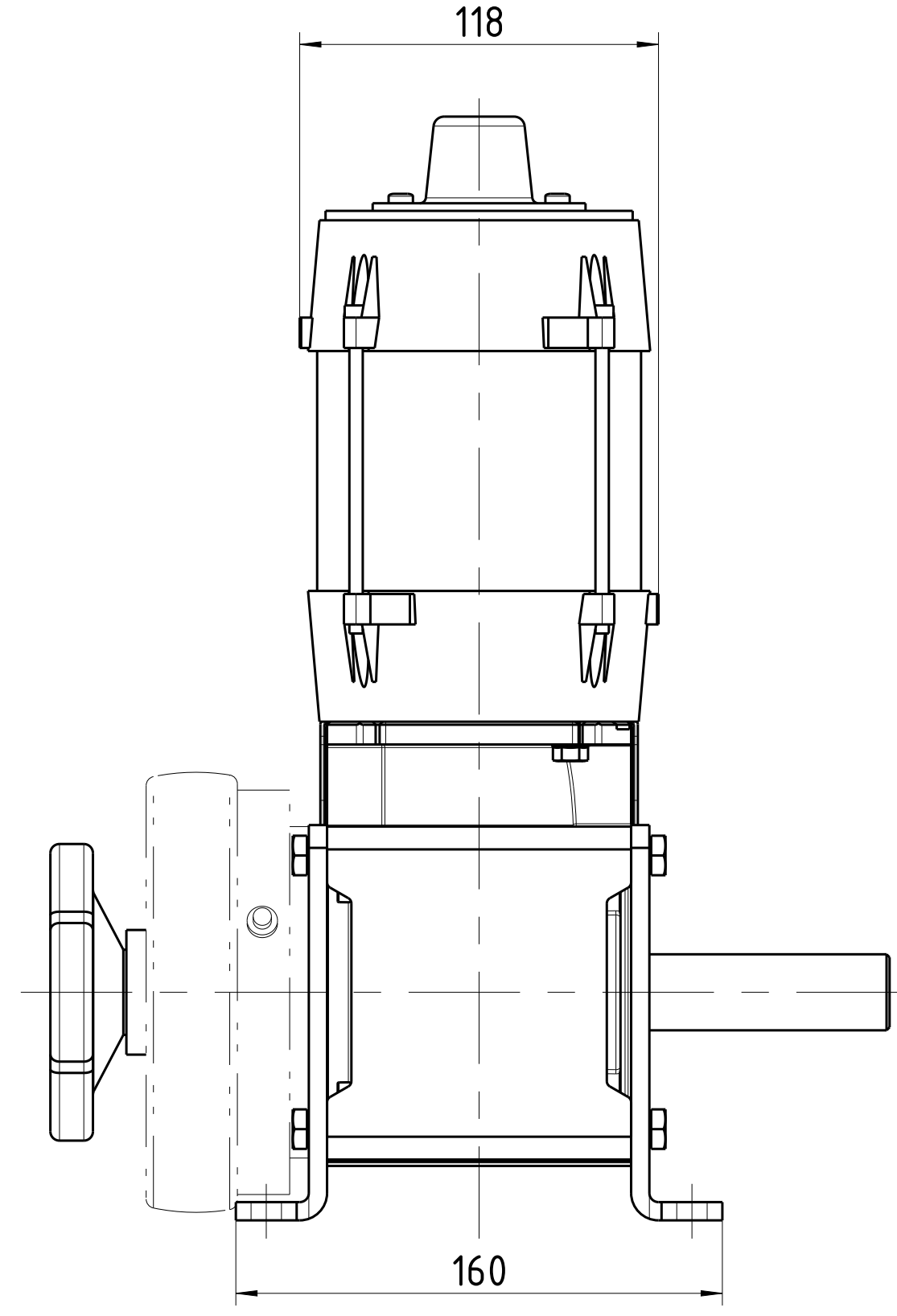
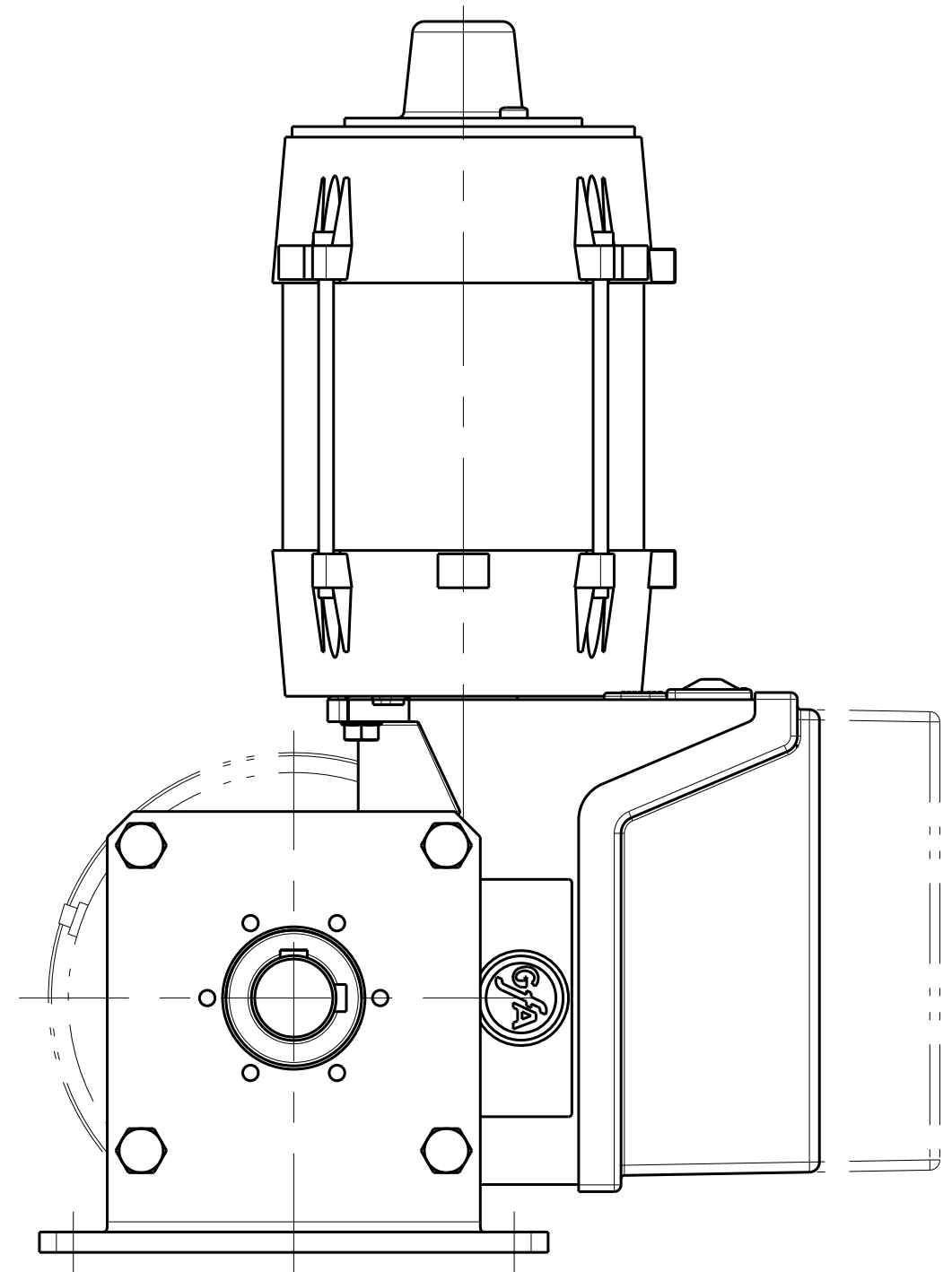
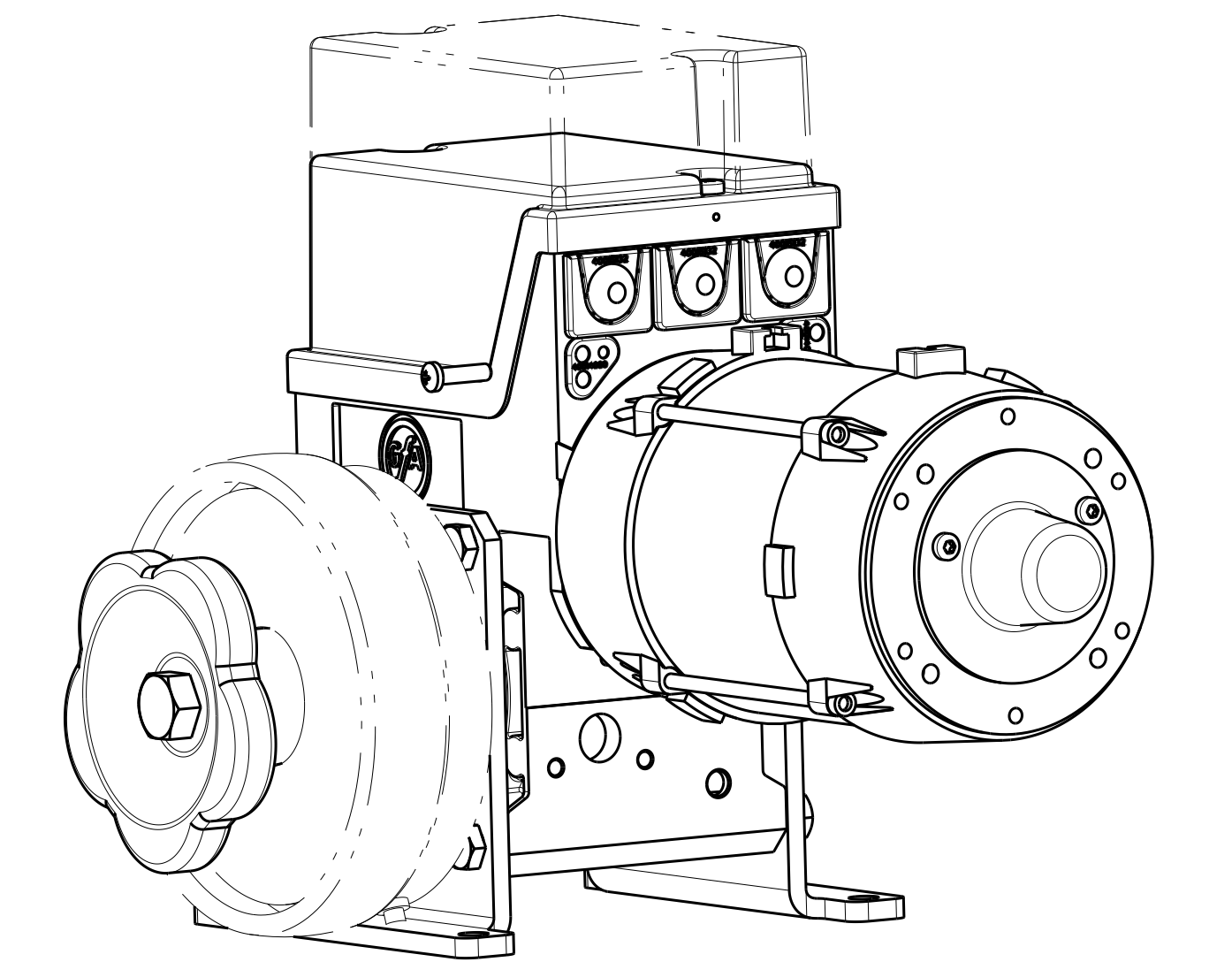
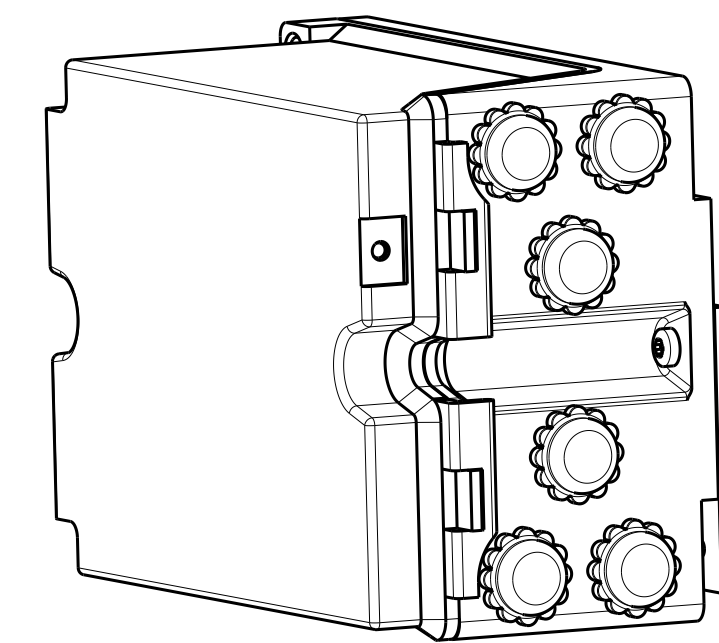
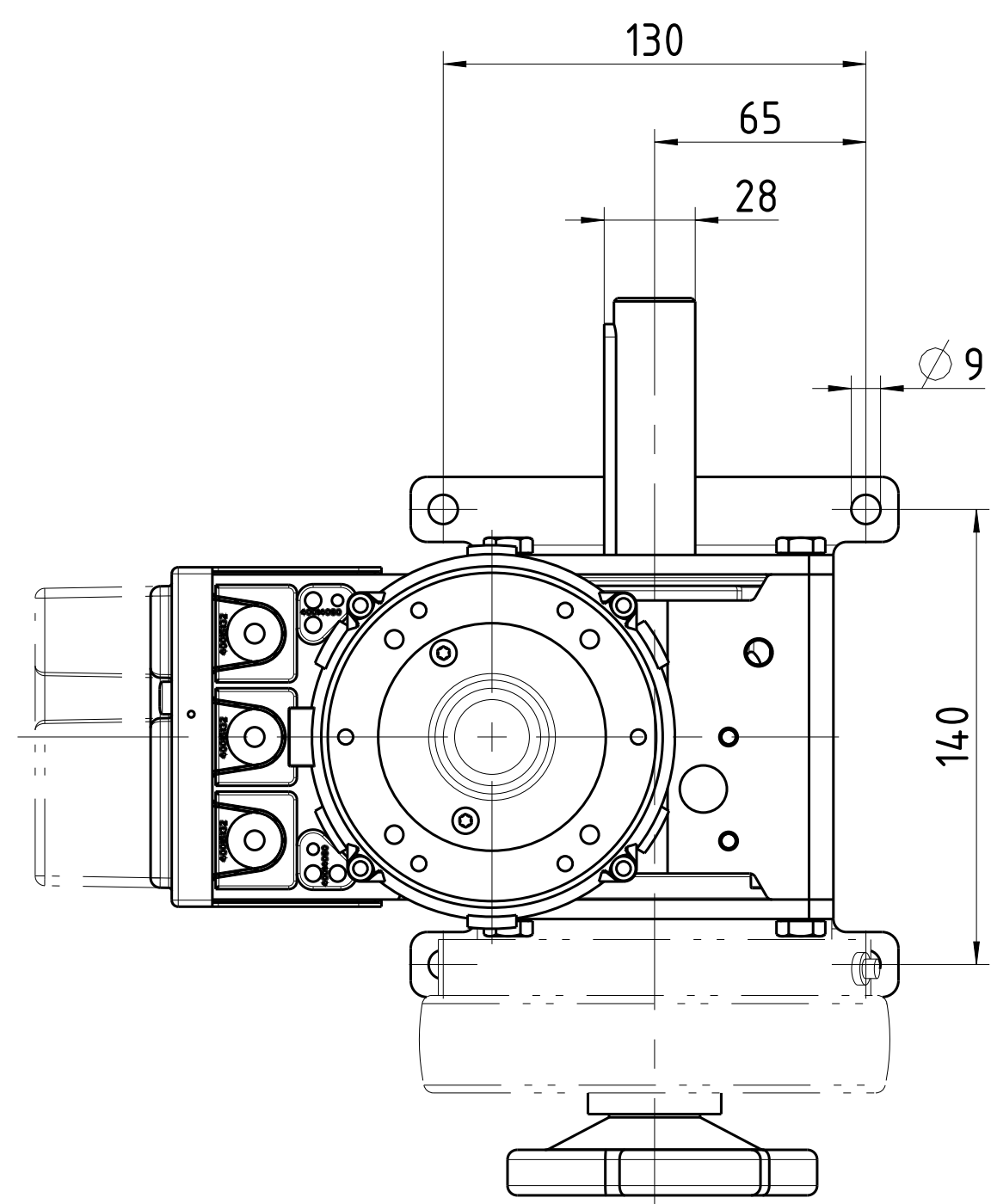
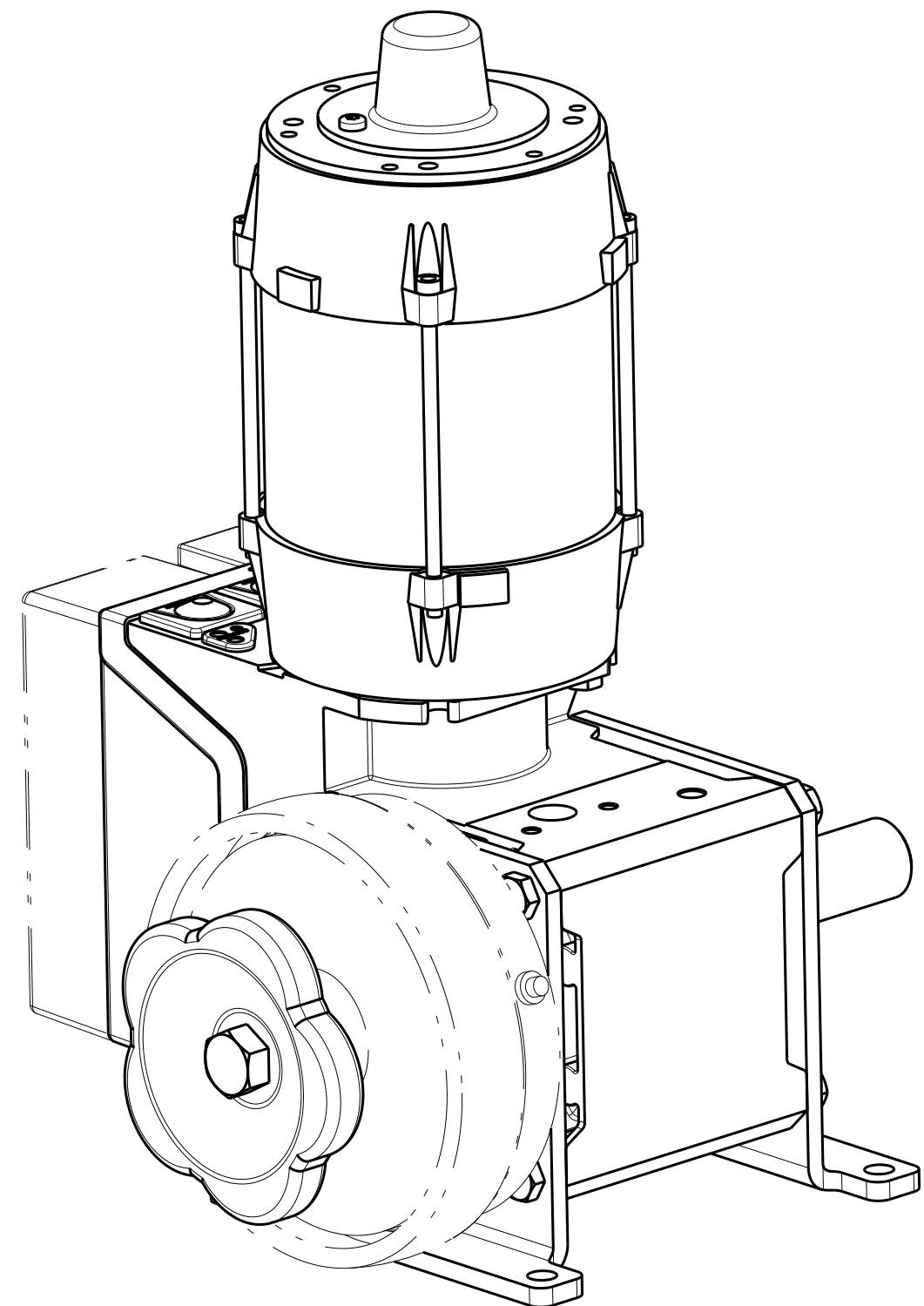

- Maß- und Konstruktionsänderungen vorbehalten  
 - Design and dimensions subject to change  
 - Sous réserves de toutes modifications techniques par le constructeur  
 - Con riserva di modifiche di dimensioni e costruzione  
 - Reservado el derecho a introducir modificaciones en las dimensiones y en la construcción

Art.-Nr.	Nm	1/min
ST 9.15	10003371	90
ST 9.24	10002917	90

Ind./Nr.	Dokumentenstatus	Ausgabedatum	Zulässige Abweichung	Maßstab	Format	Gewicht
B.4		01.06.2017	QMw00033	1:2	DIN A0	
Geprüft / Gezeichnet GFA ELEKTROMATEN Wiesenstraße 81 40549 Düsseldorf Germany Einbauezeichnung SG50R ST 9.15 / ST9.24 Art.-/Zeichnungsnummer 50000976				Werkstoff nach GFA Stückliste, bzw. Div. Besenung 4446 21 Klassifikation 1/1		